

Zahnradmotoren

- Serie XV -

Baugröße 2



Bestellnr.	Typ	Code
Reversierbar		
018-080-02200	XV2M/4-BH-Ø50-C0.002-Lecköl extern	X2M4107FRRE
018-080-02250	XV2M/6-BH-Ø50-C0.002-Lecköl extern	X2M4307FRRE
018-080-02300	XV2M/9-BH-Ø50-C0.002-Lecköl extern	X2M4507FRRE
018-080-02350	XV2M/11-BH-Ø50-C0.002-Lecköl extern	X2M4707FRRE
018-080-02400	XV2M/14-BH-Ø50-C0.002-Lecköl extern	X2M4907FRRE
018-080-02450	XV2M/17-BH-Ø50-C0.002-Lecköl extern	X2M5107FRRE
018-080-02500	XV2M/19-BH-Ø50-C0.002-Lecköl extern	X2M5307FRRE
018-080-02550	XV2M/22-BH-Ø50-C0.002-Lecköl extern	X2M5507FRRE
018-080-02600	XV2M/26-BH-Ø50-C0.002-Lecköl extern	X2M5707FSSE
018-080-02650	XV2M/30-BH-Ø50-C0.002-Lecköl extern	X2M5907FSSE
018-080-02700	XV2M/34-BH-Ø50-C0.002-Lecköl extern	X2M6107FSSE
018-080-02750	XV2M/40-BH-Ø50-C0.002-Lecköl extern	X2M6307FSSE

4-Loch-Flansch-BH-Durchschraubausführung -Bohrungsabstand = 60 x 60 mm / Rezess = Ø 50 mm / Welle -C0.002 1:5 -d = Ø 17,42 mm
-M 12x1,5 -Passfeder = 3,0 mm / max. zulässiges Wellendrehmoment = 233,2 Nm / Öllanschlüsse = Flansch LK 35/40 seitlich

Umkehrmotor - Serie XV

MOTOR TYP "BH"
FLANSCH ø50 GEFORMT - KEGELWELLE

XV-2M

X 2 M 51 07 F R R E

Serie	X	Serie XV
Gruppe	2	Gruppe 2
Kategorie	M	Umkehrmotor
Hubraum	51	17
Flansch	07	Ø50 DEUTSCHE NORM BH Drehrichtung umkehrbar
Welle	F	CO002 - Konisch 1:5 - ø17.4 - M12x1.5 - Scheibenfeder Dicke 3
Gehäuse	IN	R Ansaugung - Ø35 a 45° Ø15 M6
	OUT	R Druckseite - Ø35 a 45° Ø15 M6
Deckel	E	Mit Drainage aussen



XM210

Technische Datentabelle							
TYP	Hubraum	Maximaldruck		CODE			
		cm3/u	P1 bar	P3 bar	Drainage aussen		Drainage innen
XV-2M/04	4,20	260	300	X 2 M 41 07 F R R E	X 2 M 41 07 F R R F		
XV-2M/06	6,00	260	300	X 2 M 43 07 F R R E	X 2 M 43 07 F R R F		
XV-2M/09	8,40	260	300	X 2 M 45 07 F R R E	X 2 M 45 07 F R R F		
XV-2M/11	10,80	260	300	X 2 M 47 07 F R R E	X 2 M 47 07 F R R F		
XV-2M/14	14,40	250	290	X 2 M 49 07 F R R E	X 2 M 49 07 F R R F		
XV-2M/17	16,80	230	270	X 2 M 51 07 F R R E	X 2 M 51 07 F R R F		
XV-2M/19	19,20	210	250	X 2 M 53 07 F R R E	X 2 M 53 07 F R R F		
XV-2M/22	22,80	200	240	X 2 M 55 07 F R R E	X 2 M 55 07 F R R F		
XV-2M/26	26,20	170	210	X 2 M 57 07 F S S E	X 2 M 57 07 F S S F		
XV-2M/30	30,00	160	200	X 2 M 59 07 F S S E	X 2 M 59 07 F S S F		
XV-2M/34	34,20	150	190	X 2 M 61 07 F S S E	X 2 M 61 07 F S S F		
XV-2M/40	39,60	140	180	X 2 M 63 07 F S S E	X 2 M 63 07 F S S F		

P1) Max. Betriebsdruck - P3) Max. Druckspitze

Für schwere Anwendungen empfiehlt sich eine Prüfung des zulässigen Wellendrehmoments

Dimensionstabelle										
TYP	Gewicht	A	B	C	D	E	F	D	E	F
		mm	mm	mm	IN			OUT		
XV-2M/04	2,100	87,2	38,6	77,2	ø15	35	M6x1	ø15	35	M6x1
XV-2M/06	2,200	90,2	38,6	80,2	ø15	35	M6x1	ø15	35	M6x1
XV-2M/09	2,300	94,2	40,6	84,2	ø15	35	M6x1	ø15	35	M6x1
XV-2M/11	2,400	98,2	45,0	88,2	ø15	35	M6x1	ø15	35	M6x1
XV-2M/14	2,600	104,2	45,0	94,2	ø15	35	M6x1	ø15	35	M6x1
XV-2M/17	2,700	108,2	45,0	98,2	ø15	35	M6x1	ø15	35	M6x1
XV-2M/19	2,800	112,2	45,0	102,2	ø15	35	M6x1	ø15	35	M6x1
XV-2M/22	2,950	118,2	52,5	108,2	ø15	35	M6x1	ø15	35	M6x1
XV-2M/26	3,050	122,2	52,5	112,2	ø20	40	M6x1	ø20	40	M6x1
XV-2M/30	3,300	130,2	60,7	120,2	ø20	40	M6x1	ø20	40	M6x1
XV-2M/34	3,500	137,2	60,7	127,2	ø20	40	M6x1	ø20	40	M6x1
XV-2M/40	3,700	146,2	60,7	136,2	ø20	40	M6x1	ø20	40	M6x1

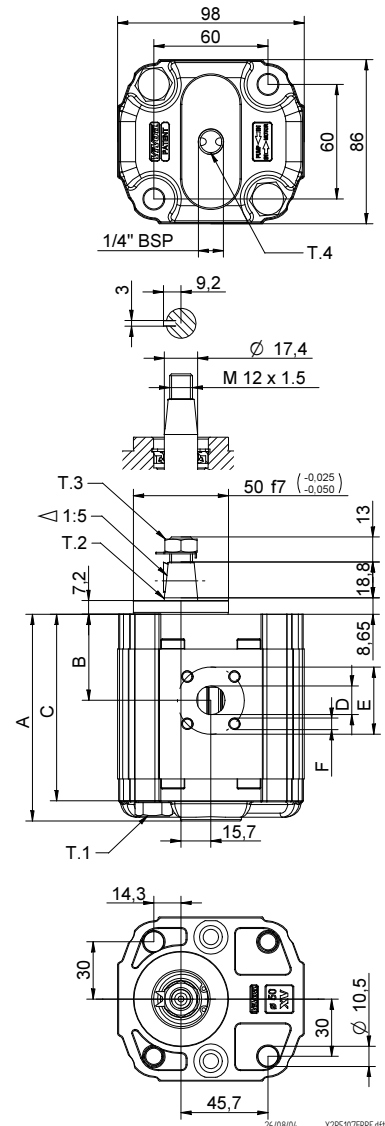

T.1 = 54±58.9 [Nm] - Anzugsmoment - Schrauben M10

T.3 = 40 [Nm] - Anzugsmoment - Schlüssel 19





T.2 = 233.2 [Nm] - zulässiges Wellendrehmoment (N.B. Zur Auswahl der Welle stets das zulässige Drehmoment prüfen).

T.4 = 0.3±0,5 bar - Drainage Maximaldruck

Tabelle der Varianten

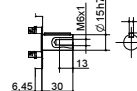
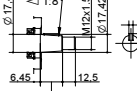
XV-2M

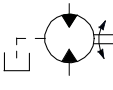
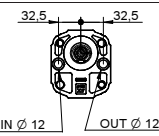
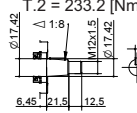
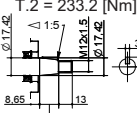
FLANSCH $\varnothing 50$ "BH" – Geformt

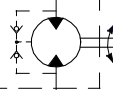
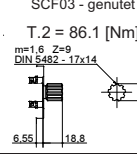
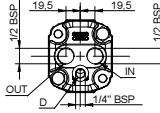
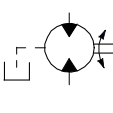
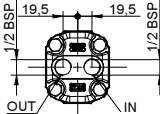
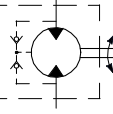
FLANSCH $\varnothing 50$ "BH" – Geformt		Welle		Deckel		
	07	CI001 - Zylindrisch T.2 = 44.1 [Nm] 	A	CI002 - Zylindrisch T.2 = 67.5 [Nm] 	B	  Drainage aussen E
	10	CO001 - Konisch T.2 = 233.2 [Nm] 	E	CO002 - Konisch T.2 = 233.2 [Nm] 	F	  Drainage innen F
		SCF03 - genutet T.2 = 86.1 [Nm] 	H			  IN + OUT + K
						  IN + OUT + L

Hubraum	
TYP	CODE
XV-2M/04	41
XV-2M/06	43
XV-2M/09	45
XV-2M/11	47
XV-2M/14	49
XV-2M/17	51
XV-2M/19	53
XV-2M/22	55
XV-2M/26	57
XV-2M/30	59
XV-2M/34	61
XV-2M/40	63

Gehäuse Standard					
Hubraum	cm ³ /u	Standardgewinde			
4		O - O	R - R	B - B	Z - Z
6		O - O	R - R	B - B	Z - Z
9		O - O	R - R	B - B	Z - Z
11		O - O	R - R	B - B	Z - Z
14		P - P	R - R	C - C	Z - Z
17		P - P	R - R	C - C	Z - Z
19		P - P	R - R	C - C	Z - Z
22		P - P	R - R	C - C	Z - Z
26		Q - P	S - S	D - D	Z - Z
30		Q - P	S - S	D - D	Z - Z
34		Q - P	S - S	D - D	Z - Z
40		Q - P	S - S	D - D	Z - Z

*Kombinationstabelle der lagermäßig vorrätigen
Standardgewinde und Anflansungen*

Gehäuse (Gewinde und Anflansungen)													
	A		B		C		D		E		F		G
	H		I		L		M		N		O		P
	Q		R		S		T		U		V		Z